

Assembly Instructions

Scape Series™

For further assembly help please view the assembly video online at:
www.bluestreakequipment.com/

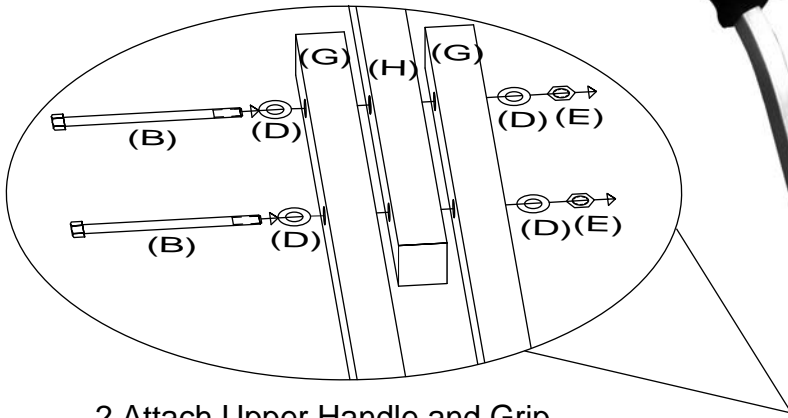

2. Attach Upper Handle and Grip

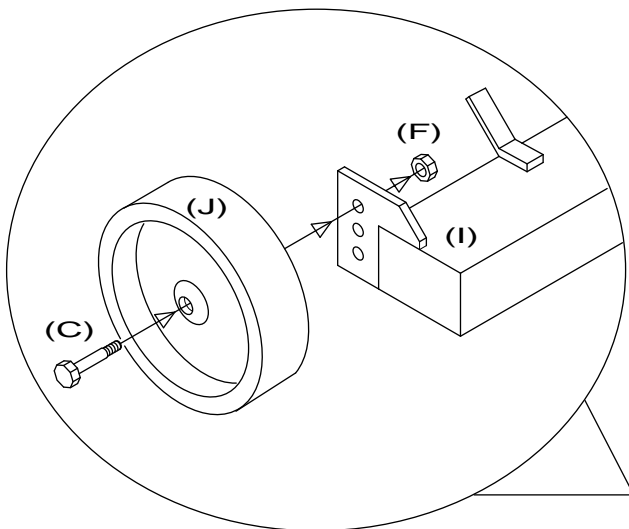

3. Wheel Assembly

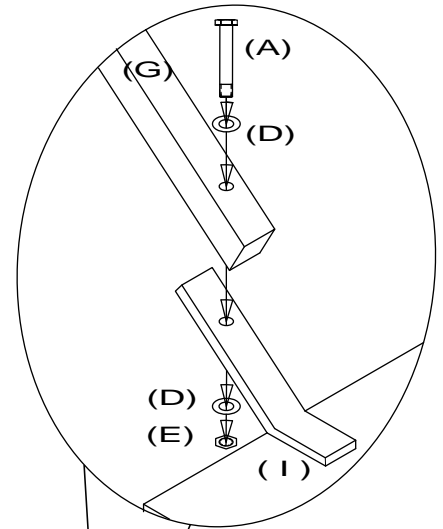

1. Attaching Lower Y-Handle Arms

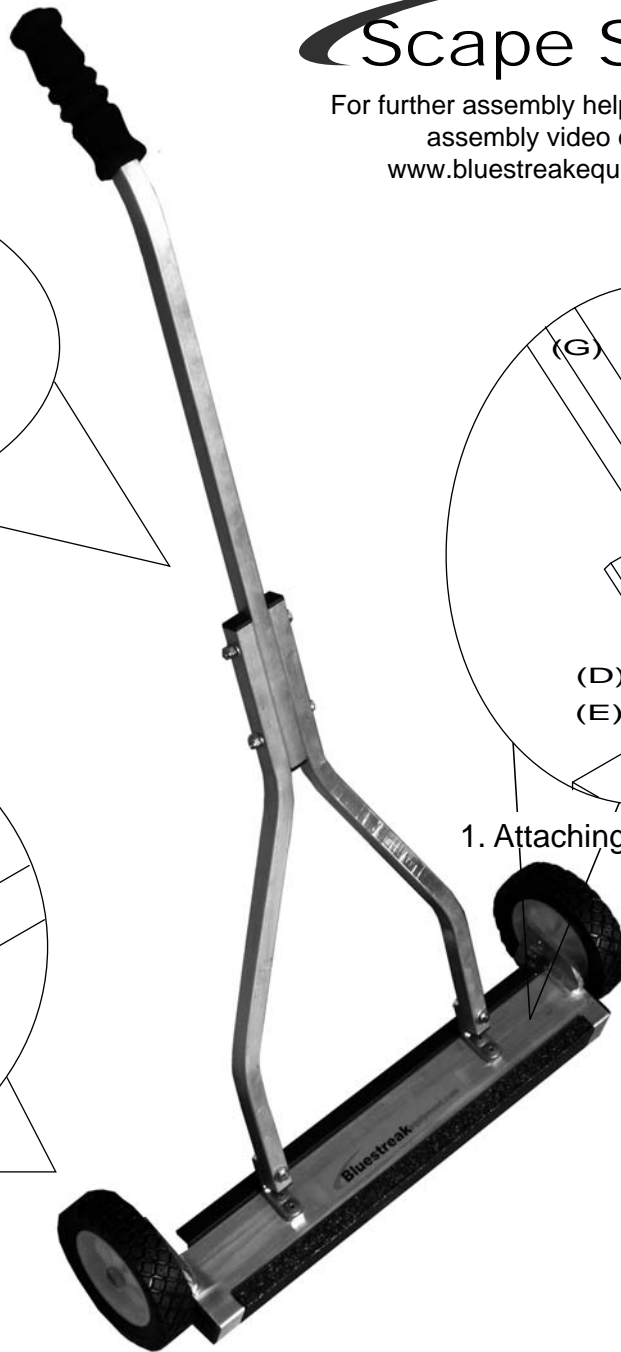

Scape Series Assembly Instructions

(1) Lower Y-handle Arms (Item G) are installed on the front of the uprights of the Magnetic Sweeper Assembly (Item I). Attach Lower Y-handle Arms (Item G) to Magnetic Sweeper Assembly (Item I) Using 2 (1/4" x 1 1/2") Hex Bolts (Item A), 4 Washers (Item D), and 2 Hex Nuts (Item E). Do not tighten bolts until completing step (2)

(2) Attach Upper Handle and Grip (Item H) to Lower Y-handle Arms (Item G) using 2 (1/4" x 2 3/4") Hex Bolts (Item B), 4 Washers (Item D), and 2 Hex Nuts (Item E). Tighten all bolts firmly using two 7/16" wrenches.

(3) Insert 1/2" Wheel Bolts (Item C) through 6" Wheels (Item J), through desired hole location on Magnetic Sweeper Assembly (Item I) and tighten 3/8" Flanged Hex Nut (Item F), using a 9/16" and 3/4" wrench. Repeat for opposite side.

What's in the box

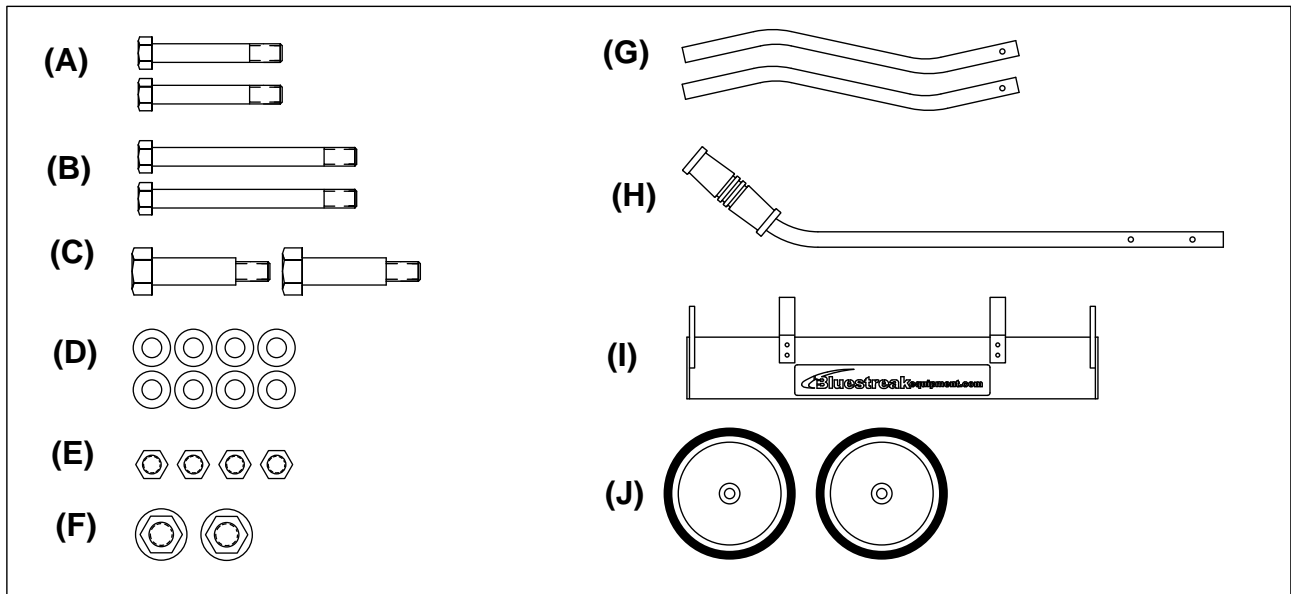

Item	Quantity	Description
(A)	2pcs	1/4" x 1 1/2" Hex Bolts
(B)	2pcs	1/4" x 2 3/4" Hex Bolts
(C)	2pcs	1/2" Wheel Bolts
(D)	8pcs	1/4" Washers
(E)	4pcs	1/4" Hex Nuts
(F)	2pcs	3/8" Flanged Hex Nut
(G)	2pcs	Lower Y-handle Arms
(H)	1pc	Handle and Grip
(I)	1pc	Magnetic Sweeper Assembly with ABS Quick Clean Sleeve
(J)	2pcs	6" Wheels

Tools Needed:

7/16" wrench x 2

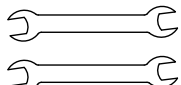

9/16" wrench x 1

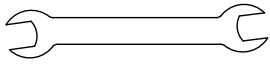

3/4" wrench x 1

